



► FEATURES

- Selectable weighing unit
- Percentage weighing, counting, accumulation
- Attached wind shielding (capacity≤1500g)

► OPTIONS

- RS-232 can connect to computer, LP-50 Label printer or TPuP mini printer
- Below weighing

► DIMENSION(mm)

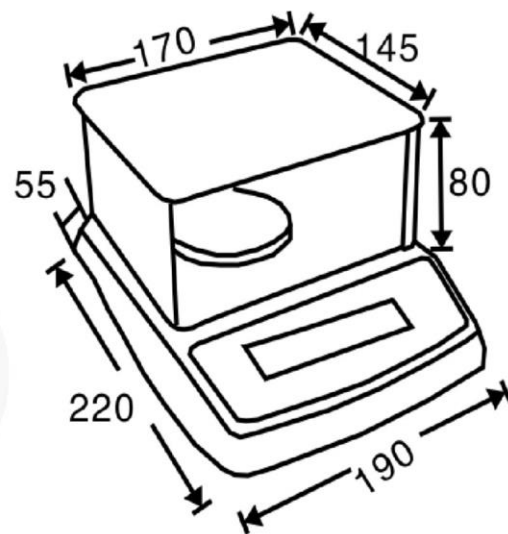

► SPECIFICATIONS

MODEL	TB	THB
Display	15mm LCD, Attached LED backlight	
Keyboard	7keys	
Pan size	Round 120 (≤1kg) , 124X144(>1kg)	
Capacities	300g/600g/1500g/3000g	
Max. Divisions	30,000d	60,000d
Operate temp	0°C~+40°C	
ADC	sigma delta	
ADC update	≤1/10 second	
Housing	ABS plastic	
Power	AC adapter (9V/800mA) Internal rechargeable battery (6V/1.2 Ah)	
Gross weight	2.3kg	
Packing	Master carton 4 in 1 Gross weight 11kg dimension 0.09m ³ , 40 feet container can load 2400 machine, 20 feet container can load 1200 machine	